

# SmartDispenser® GENIUS® POSILOK™ DISPENSE TIP SELECTION CHARTS

## SELECTION CHART

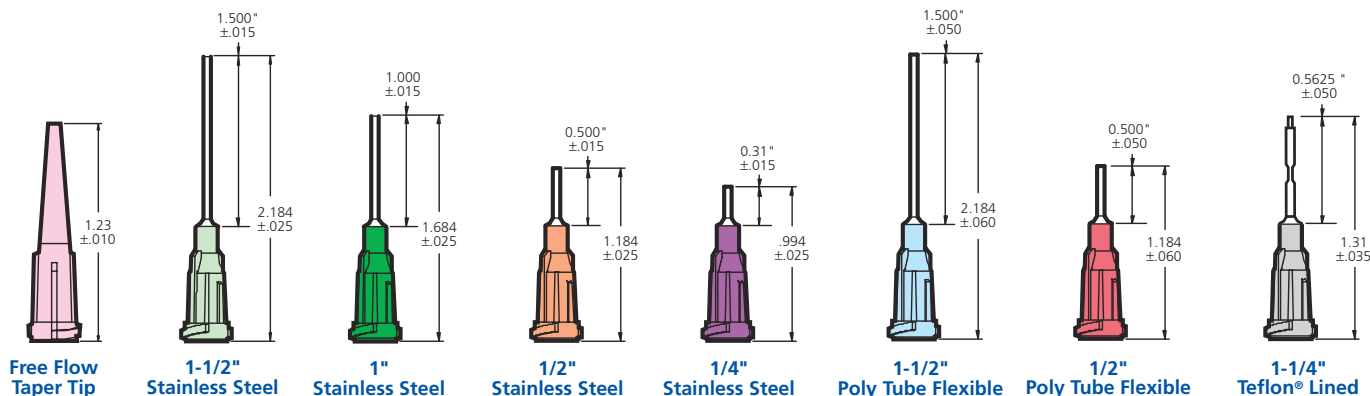

FLUIDS	Stainless Steel Tip	Tapered Tip	FlexiTip Teflon®	Lined Tip
Adhesives	◆	◆	◆	◆
Anaerobics	●	◆	◆	●
Conformal coatings	●	◆	●	+
Cyanoacrylates	●	◆	◆	◆
Gel cyanoacrylates	●	◆	◆	●
Epoxies	◆	◆	◆	+
Greases	◆	◆	◆	+
Light-cure Adhesives	●	+	●	+
Oils	◆	●	◆	●
Paints	◆	●	◆	+
Sealants	●	◆	●	+
Solder creams/Braze pastes	◆	◆	●	+
Solder masks	◆	◆	●	+
Solvents	●	◆	◆	◆
UV-cure adhesives	●	◆	●	●

◆ Recommended ● Satisfactory + Do not use

APPLICATIONS	Stainless Steel Tip	Tapered Tip	FlexiTip Teflon®	Lined Tip
Low viscosity fluids	◆	●	◆	◆
Particle filled pastes	◆	◆	●	+
Microdots	◆	+	●	●
Metal reactive fluid	+	◆	◆	◆
Dispensing into crevasses	◆	●	◆	●
Spreading/smearing	●	◆	◆	●
Fast curing glues	●	◆	◆	◆
Beading	◆	◆	◆	●
Sensitive surfaces-avoid scratching	●	◆	◆	◆

◆ Recommended ● Satisfactory + Do not use

Selecting the appropriate dispense tip for your assembly fluid and application optimizes the performance of your dispensing system. Refer to the various selection guides or contact one of our Customer Service Representatives for assistance at 800-433-2115



# SmartDispenser® GENIUS® POSILOK™ DISPENSE TIP SELECTION CHARTS

## SELECTION CHART

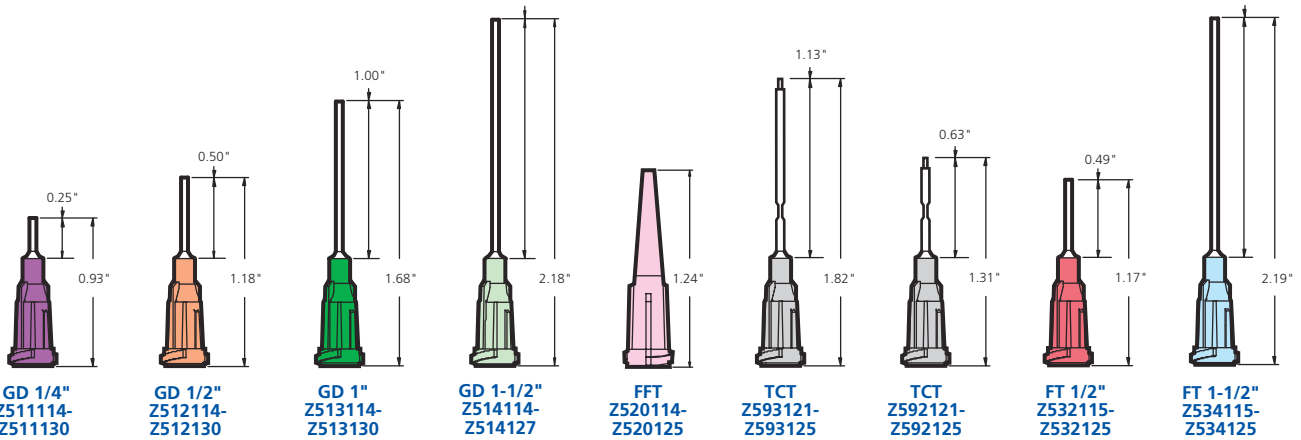

### GD™ Global Dispense Tips (Stainless steel tips, polypropylene hubs)

Part Number*	Color	Size	ID	OD	ID	OD
Z512114	White	14 ga.	.0595-.0615	.0715-.0725	1.51-1.56	1.82-1.84
Z512115	Amber	15 ga.	.0525-.0545	.0645-.0655	1.33-1.38	1.64-1.66
Z512116	Dk. Purple	16 ga.	.0455-.0485	.0645-.0655	1.15-1.23	1.63-1.66
Z512118	Green	18 ga.	.0315-.0345	.0495-.0505	0.80-0.88	1.26-1.28
Z512119 Lt.	Green	19 ga.	.0255-.0285	.0415-.0425	0.64-0.72	1.05-1.07
Z512120	Pink	20 ga.	.0230-.0245	.0355-.0360	0.58-0.62	0.90-0.91
Z512121	Purple	21 ga.	.0195-.0210	.0320-.0325	0.50-0.53	0.81-0.83
Z512122	Blue	22 ga.	.0155-.0170	.0280-.0285	0.39-0.43	0.71-0.72
Z512123	Orange	23 ga.	.0125-.0140	.0250-.0255	0.32-0.36	0.64-0.65
Z512125	Red	25 ga.	.0095-.0110	.0200-.0205	0.24-0.28	0.51-0.52
Z512127	Clear	27 ga.	.0075-.0090	.0160-.0165	0.19-0.23	0.41-0.42
Z512130	Lavender	30 ga.	.0055-.0070	.0120-.0125	0.14-0.18	0.30-0.32
Z511132**	Yellow	32 ga.	.0035-.0050	.0090-.0095	0.09-0.13	0.23-0.24

\*Note: When ordering, change 4th digit for correct tip length: 1=.25"; 2=.5"; 3=1"; 4=1.5" \*\*Note: 32 ga comes in .25" only.

### FFT™ FreeFlow™ Tips (Polyethylene)

Part Number*	Color	Size	ID (in.)	ID (mm)
Z520114	White	14 ga.	.063	1.60
Z520116	Grey	16 ga.	.047	1.19
Z520118	Green	18 ga.	.033	0.84
Z520120	Pink	20 ga.	.023	0.58
Z520122	Blue	22 ga.	.016	0.41
Z520125	Red	25 ga.	.010	0.25

### TCT™ Teflon®-lined Crimped Tips

Part Number*	Color	Size	OD-A (in.) Stainless outer	OD-B (in.) Teflon® lining	OD-A (mm) Stainless outer	OD-B (mm) Teflon® lining
Z592121	Grey	21 ga.	.065	.041	1.65	1.04
Z592125	Pink	25 ga.	.050	.028	1.27	0.71

\*Note: When ordering, change 4th digit for correct tip length: 2=.5"; 3=1" — A - Outer Tube OD (Stainless); B - Inner Tube OD (Teflon®)

### FT™ FlexiTips™ (polypropylene)

Part Number*	Color	Size	ID (in.)	OD (in.)	ID (mm)	OD (mm)
Z532115	Amber	15 ga.	.049	.063	1.24	1.60
Z532118	Green	18 ga.	.032	.048	0.81	1.22
Z532120	Pink	20 ga.	.019	.034	0.48	0.86
Z532125	Red	25 ga.	.014	.030	0.35	0.77

\*Note: When ordering, change 4th digit for correct tip length: 2=.5"; 4=1.5"

Teflon® is a registered trademark of DuPont Corporation. GD, FFT, FreeFlow, TCT, FT and FlexiTip are trademarks of Fishman Corporation. © 2005 Fishman Corporation

Fishman Corporation 192 South Street, Hopkinton, MA 01748, United States  
US & Canada: 800-433-2115 | United Kingdom: 1905 456008 | Europe: +441905 456008  
Worldwide: 1-508-435-2115 | www.fishmancorp.com

**FISHMAN**®  
Dispensing Innovation®